



# Technical Data Sheet Type 51TH



Type 51TH

2/2-way solenoid valve  
 NC - Valve normally closed (as standard)  
 NO - Valve normally open (as option)

Pilot operated piston design. The mentioned minimum pressure difference between inlet and outlet is necessary for proper operation.  
 In standard (NC) the valve closes with spring power.

■ Solenoid valve for extended temperature range

## TECHNICAL SPECIFICATIONS

Type of control	Pilot operated, pressure difference is required
Design	Pistondesign
Connection	Threaded G1/4 - G2 DIN ISO 228/1 (BSP) <small>Other connections like NPT on request</small>
Installation	Preferable with actuator upright
Pressure	0,5 - 40 bar (see table page 2)
Medium	Clean, neutral, gaseous and liquid medium
Viscosity	22 mm <sup>2</sup> /s
Temperature range	Medium: -20 °C bis +180 °C Ambient: -20 °C bis +50 °C  <small>In consideration of the restrictions described on page 4</small>
Body material	Brass 2.0402 Stainless steel 1.4581
Metallic inner parts	Brass and stainless steel
Sealing	PTFE
Supply voltage	AC~ 24V, 110V, 230V DC= 12V, 24V <small>Other supply voltages on request</small>
Voltage tolerance	-10% / +10%
Power consumption	D182 = 6,8 Watt D012 = 18 Watt
Protection class	IP65 nach DIN 60529
Duty factor	100% ED-VDE 0580
Connection type	Plug

## VALVE FEATURES

- For media temperatures up to +180 °C
- Pressure difference is required
- High life time
- Simple compact valve design
- High-quality materials
- Reliable and sturdy sealing elements

## FUNCTION

NC – non energized closed

NO – non-energized open

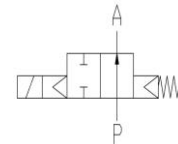
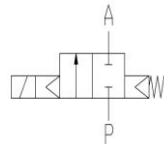

## CERTIFICATES



## ORDERING SYSTEM

Valve type			Coil system	Valve options
5	1	2 3	D 1 8 2	- T H
/ 1 0 0 4 /			D Temperature design	TM +140 °C
Connection		Body material		Seal material
21	G 1/4	10	Brass 2.0402	04 PTFE
22	G 3/8	08	Stainless steel 1.4581	
23	G 1/2			
24	G 3/4			
25	G 1			
26	G 1 1/4			
27	G 1 1/2			
28	G 2			



TE-HA-BUD Sp. z o.o.

ul. Winna 19, 61-658 Poznań  
 tel.: 61 / 825-95-66, 61 / 852-76-49  
 fax: 61 / 851-69-19  
 e-mail: [zawory@zawory.com.pl](mailto:zawory@zawory.com.pl)



# TECHNICAL FEATURES

G	Seat mm	Kv-value m <sup>3</sup> /h	Standard type	max. pressure for coils <b>NC</b>	
				D182	D012
1/4	13,5	1,8	.5121/.../....-TH	0,5-16	0,5-40
3/8	13,5	4,0	.5122/.../....-TH	0,5-16	0,5-40
1/2	13,5	1,5	.5123/.../....-TH	0,5-16	0,5-40
3/4	27,5	11,5	.5124/.../....-TH	0,5-16	0,5-40
1	27,5	13,0	.5125/.../....-TH	0,5-16	0,5-40
1 1/4	40	29,0	.5126/.../....-TH	-	0,5-40
1 1/2	40	33,0	.5127/.../....-TH	-	0,5-40
2	50	49,0	.5128/.../....-TH	-	0,5-40

The flow rate mentioned in the table applies to the strongest coil.

G	Seat mm	Kv-value m <sup>3</sup> /h	Standard type	max. pressure for coils <b>NO</b>	
				D182	D012
1/4	13,5	1,8	.5121/.../....-TH	-	0,5-40
3/8	13,5	4,0	.5122/.../....-TH	-	0,5-40
1/2	13,5	1,5	.5123/.../....-TH	-	0,5-40
3/4	27,5	11,5	.5124/.../....-TH	-	0,5-40
1	27,5	13,0	.5125/.../....-TH	-	0,5-40
1 1/4	40	29,0	.5126/.../....-TH	-	0,5-16
1 1/2	40	33,0	.5127/.../....-TH	-	0,5-16
2	50	49,0	.5128/.../....-TH	-	0,5-16

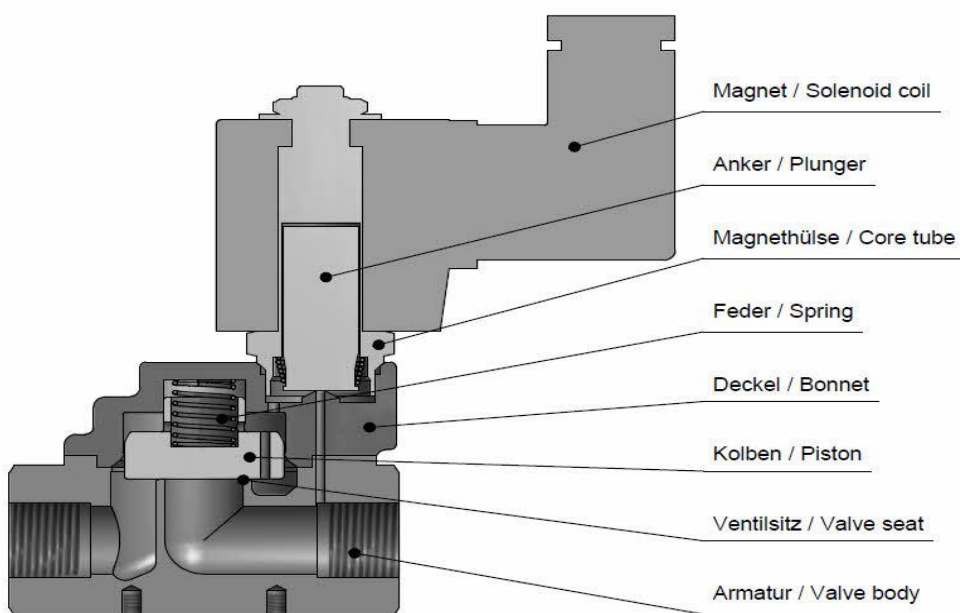

## DIMENSIONS

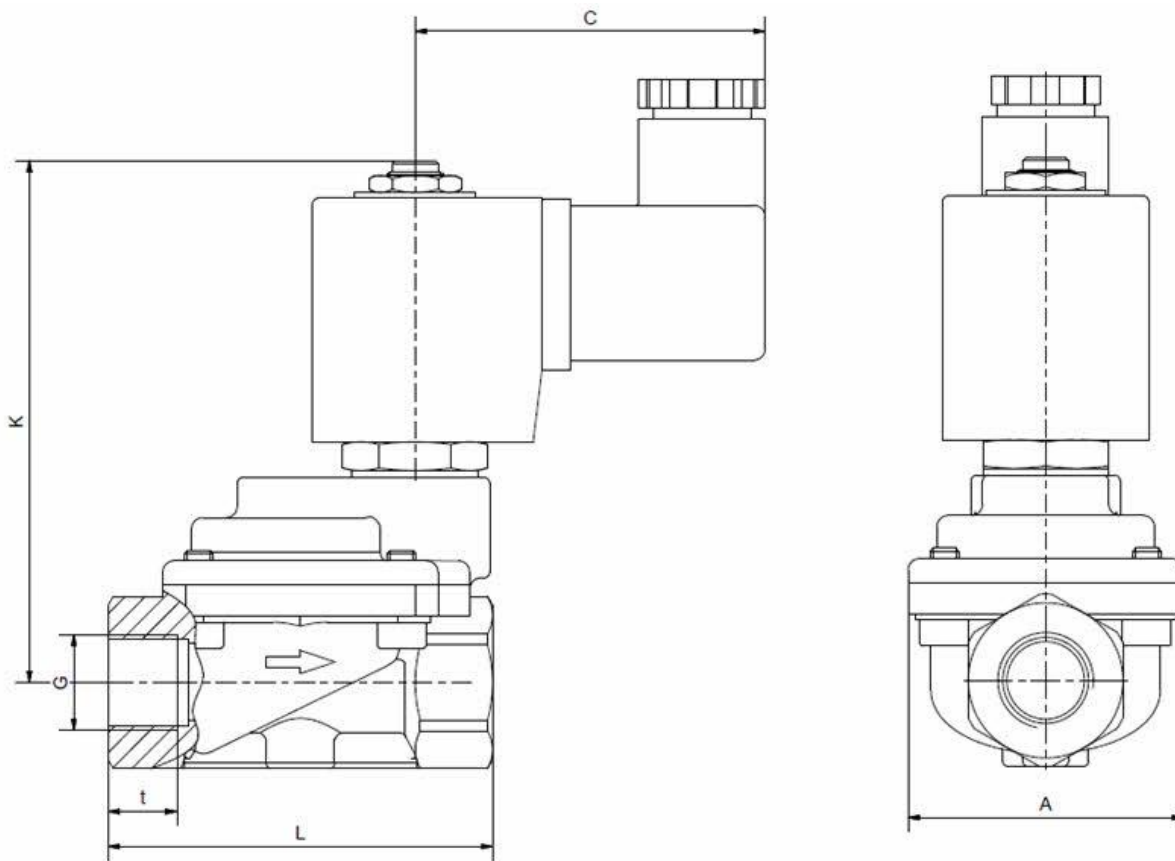

Coil	D182				
Type	5121	5122	5123	5124	5125
G	1/4	3/8	1/2	3/4	1
A	48	48	48	70	70
C	51	51	51	51	51
K	75	75	75	91	91
L	67	67	67	96	96
t	12	12	12	16	16
kg	0,9	0,85	0,8	1,8	1,65

Coil	D012							
Type	5121	5122	5123	5124	5125	5126	5127	5128
G	1/4	3/8	1/2	3/4	1	1 1/4	1 1/2	2
A	48	48	48	70	70	96	96	112
C	61	61	61	61	61	61	61	61
K	90	90	90	106	106	128	128	140
L	67	67	67	96	96	140	140	168
t	12	12	12	16	16	22	22	22
kg	0,9	0,85	0,8	1,8	1,65	3,8	3,5	5,2

## INFORMATION

- It is imperative to observe the installation and safety instructions in our operating and service manuals.
- For information on our GSR ordering code, please refer to our catalogs. If you have any questions, we will be glad to assist you.
- Required ordering information: valve type, function NC/NO, pressure range, connection, nominal width, medium, flow rate, medium and ambient temperatures, connection voltage.
- **Detailed production-specific drawings and other technical information will be made available when an order is placed**

## PLEASE NOTE

Each individual application decides which valve type is required, the main factor being the resistance of the materials to the operating medium. The correct selection of materials requires knowledge of the concentration, temperature and degree of contamination of the medium. Other criteria include the operating pressure and max. volumetric flow, since, in addition to high temperatures, high pressures and high flow rates must also be taken into account when selecting the materials.

**All materials used for our valves, be it housing, seals or magnets, will be carefully selected in view of the different application areas. Any information given is non-binding and serves for orientation only. No claims under warranty can be derived therefrom.**

## Heating and power of solenoid coils

The GSR default solenoid valves are designed for continuous operation (100% ED = power-on time) under normal operating conditions. The pulling force of a solenoid coil is basically influenced by three elements:

- The self-heating of the magnetic coil
- The medium temperature
- The ambient temperature

GSR solenoid coils are by default designed for a maximum ambient temperature of +40 °C. This specification applies for the maximum allowable operating pressure specified in the data sheet of the corresponding valve and a medium temperature of +80 °C.

A higher ambient temperature is possible, when lower values are applied for the other influencing parameters. When the max. operation pressure and max. ambient temperature of +50 °C is given the medium temperature is not allowed to be higher than max. +180 °C. In addition to that, deviations from the default design temperature range are possible, e.g. when temperature coils or other constructive measures are used. Please contact the GSR headquarters to discuss the specific application.

More precise specifications and technical data with regard to the operating conditions can be found in the data sheets of the solenoid coils and the solenoid valve regarded. Please observe that the surface temperature of a permanently loaded coil can amount up to +120 °C, solely by the self-heating of the coil. The power consumption of our default solenoid valves was calculated to DIN VDE 05820 for a coil temperature of +20 °C.

- The GSR logo is a registered trademark of GSR Ventiltechnik GmbH & Co. KG.
- Note: All texts and images are the property of GSR Ventiltechnik GmbH & Co. KG and must not be replicated or modified, not even in part, without written approval.
- Original products may differ from the product images shown, due to different materials and the like.
- Subject to error and changes.

**Stand: 11.16, MK-MG, Version 1.**